



**SILKO**  
EXTREME

**SILKO**  
EXTREME



## Silko Extreme

Powerful and solid, Silko Extreme is ideal for the most challenging restaurant services, where efficiency and flexibility are at the service of the needs of those who work in this sector.

—  
*Potente e solida, Silko Extreme rappresenta la soluzione ideale per i servizi di ristorazione più impegnativi, dove efficienza e flessibilità sono al servizio delle esigenze di chi opera in questo settore.*



Maximum Performance, Ergonomy, Strength & Technology  
*Massime Prestazioni, Ergonomia, Forza e Tecnologia*

High quality,  
maximum  
productivity

---

*Alta qualità,  
massima  
produttività*

Extreme completes the traditionally equipped kitchen to increase its production capacity and expand the variety of the daily menu. Ideal for fast food, production centers and restaurant chains, it combines maximum production efficiency with the quality of a product built to last over time. The best production standards are guaranteed thanks to technological systems that allow you to control time and temperature with the utmost precision.

---

*Extreme completa la dotazione tradizionale della cucina per aumentarne la capacità produttiva e ampliare la varietà del menù giornaliero. Ideale per fast food, centri di produzione e catene di ristorazione, unisce massima efficienza produttiva alla qualità di un prodotto nato per durare nel tempo. I migliori standard produttivi sono garantiti grazie a sistemi tecnologici che permettono di controllare tempi e temperature con la massima precisione.*





Our history  
is our heritage

---

*La nostra storia  
è il nostro “heritage”*

The evolution always has its origin in the past. Silko's heritage is based on a long tradition animated by the passion and dedication to a successful project. These are the factors that continue to inspire our designers, who with competence and vision, created Silko Extreme.

---

*L'evoluzione trae sempre origine dal passato. La storia di Silko si fonda su una lunga tradizione animata dalla passione e dalla dedizione ad un progetto di successo. Sono questi i fattori che continuano ad ispirare i nostri tecnici, che con competenza e visione, hanno creato Silko Extreme.*

Fast and accessible  
technical assistance  
and maintenance

---

## *Manutenzione e assistenza tecnica veloci ed accessibili*

The range consists of six free-standing models. Easy of operations are the main features of the project. An innovative opening allows easy access to components of the machinery. Reduced intervention and maintenance times contribute to decreased management costs.

---

*La gamma è composta da sei modelli free standing. Robustezza e semplicità di intervento sono tra le principali caratteristiche del progetto.*

*Un sistema innovativo di apertura del piano permette un facile accesso alle componenti tecniche delle macchine. Tempi ridotti di intervento e di manutenzione contribuiscono a diminuire i costi di gestione.*



Silko Extreme is your ideal partner in the kitchen, even when the work pace gets frantic. A well organized environment, where everything functions in an efficient way, transforming the biggest challenges in gratifying professional experiences.

*Silko Extreme è il tuo partner ideale in cucina anche quando i ritmi di lavoro diventano frenetici. Un ambiente ben organizzato, dove tutto funziona in modo efficiente, trasforma anche le sfide più impegnative in esperienze professionali appaganti.*





# Ergonomy and performance

## Ergonomia e prestazioni

Expert chefs have supported our engineers in the development of the range of products in order to optimize performance and to fully meet the needs of those working in the kitchen. For this reason, Silko Extreme offers ergonomic and simple to use machines, able to facilitate the flow and increase productivity in the kitchen, reducing the time for cleaning and maintenance.

*Chef esperti hanno affiancato i nostri tecnici nello sviluppo della gamma al fine di ottimizzarne le prestazioni e rispondere pienamente alle esigenze di chi lavora in cucina. Per questo Silko Extreme offre macchine ergonomiche e semplici da utilizzare, in grado di facilitare il flusso di lavoro e aumentare la produttività in cucina, riducendo i tempi di pulizia e manutenzione.*

1



Electric  
Multi-cooking

*Multicooking  
Elettrica*

2



Electric  
Fryer

*Friggitrice  
Elettrica*

3



Electric  
Griddle

*Plancha  
Elettrica*

4



Fry Top  
Gas/El

*Fry Top  
Gas/El*

5



Gas  
Grill

*Griglia  
Gas*

6



Refrigerated  
Counter

*Base  
Refrigerata*

7



Electric  
Salamander

*Salamandra  
Elettrica*



---

Electric griddle  
*Plancha elettrica*

1000x920x280 mm  
Kw 16 (4x4)  
Vac 400 3N 50/60 Hz

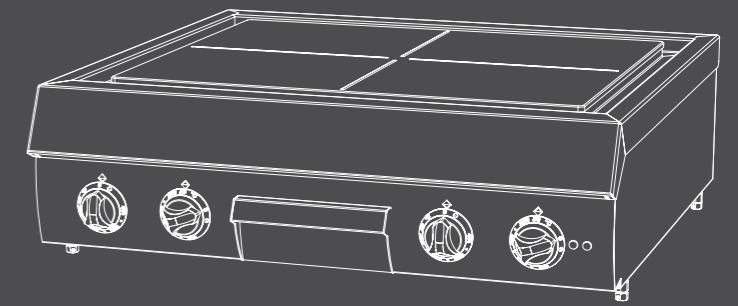

---

Fry top gas/el  
*Fry Top gas/el*

GAS  
1200x920x280 mm  
Kw 32

ELECTRIC  
1200x920x280 mm  
Kw 22.5 (3x7.5)  
Vac 400 3N 50/60 Hz

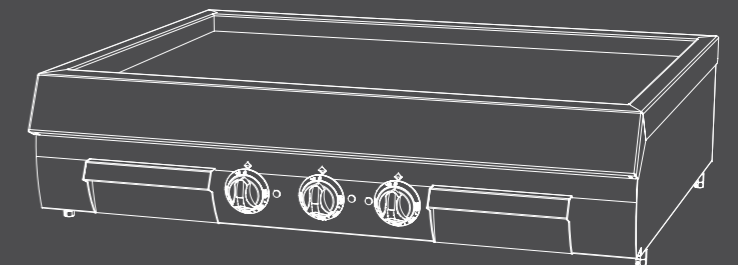

---

Gas grill  
*Griglia gas*

1200x920x280 mm  
Kw 32

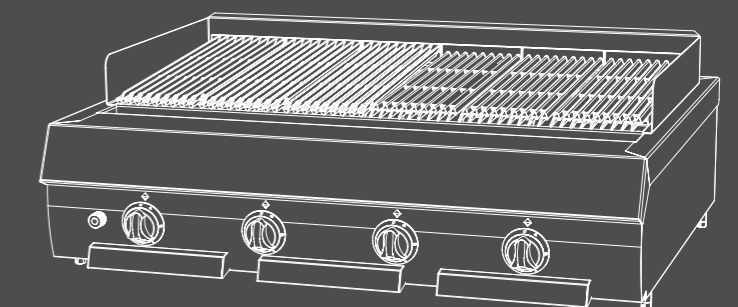

## Electric fryer *Friggitrice elettrica*

400x920x900 mm  
Kw 20  
Vac 400 3N 50/60 Hz

Basin capacity 20 lt  
*Capacità vasca 20 lt*

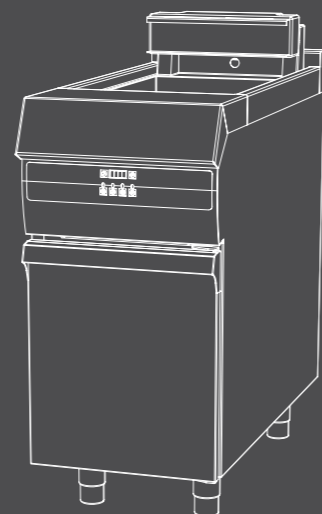

## Refrigerated counter *Base refrigerata*

TN -2° +8°  
1000x810x590 mm  
kw 0,25 Vac 230 50/60 Hz  
1200x810x590 mm  
Kw 0,49 Vac 230 50/60 Hz

BT -15° -20°  
1000x810x590 mm  
Kw 0,50 Vac 230 50/60 Hz  
1200x810x590 mm  
Kw 0,60 Vac 230 50/60 Hz

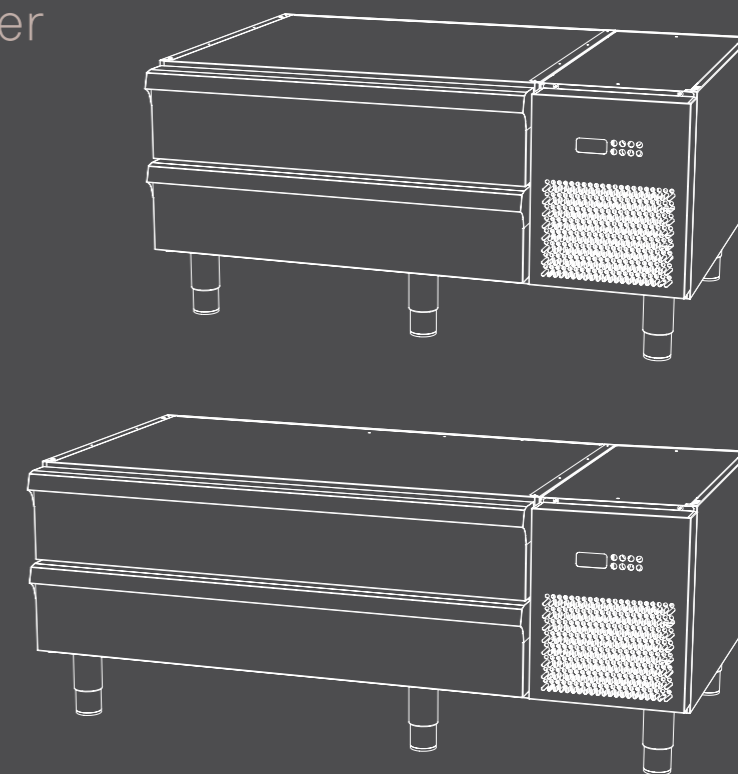

## Electric multi-cooking *Multicooking elettrica*

650x920x900 mm  
Kw 12  
Vac 400 3N 50/60 Hz

Basin capacity 20 lt  
*Capacità vasca 20 lt*

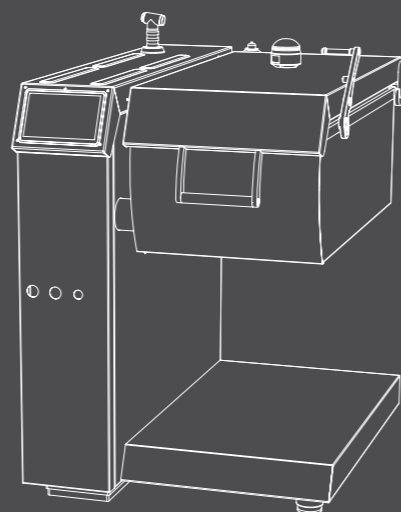

## Floor stand *Base cavalletto*

1000x725x660 mm  
1200x725x660 mm

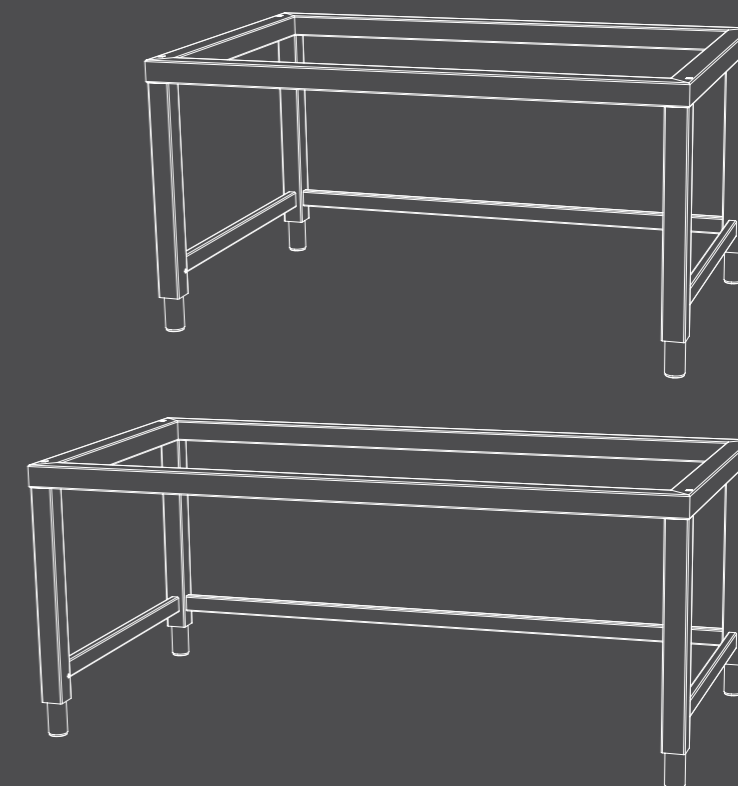

## Electric roaster *Salamandra elettrica*

600x540x500 mm  
Kw 4,5 Vac 400 3N 50/60 Hz

755x540x500 mm  
Kw 6 Vac 400 3N 50/60 Hz

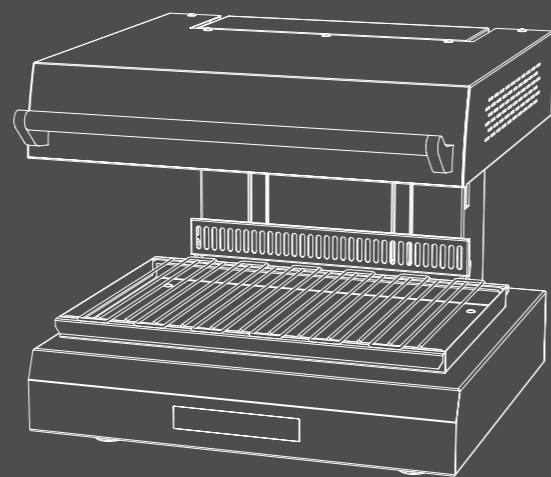

## Electric fryer

## Friggitrice elettrica

High volume electric fryer, 20 liter tank, electronic control with 4 preset cycles (modifiable by the user), automatic filtering system to ensure a longer life of the oil. The system is integrated into the fryer, thus assisting the user in the operation of cleaning the oil. Series includes: 2 baskets of 1/2, 1 cover and one residue net.

*Friggitrice elettrica, ad alta resa, con vasca da 20 litri, controllo elettronico con 4 cicli preimpostati (modificabili dall'utente), sistema di filtraggio automatico per garantire una maggiore durata dell'olio. Il sistema è integrato nella friggitrice e facilita quindi l'operatore nell'operazione di pulizia dell'olio. Dotazione di serie: 2 cestelli da 1/2, 1 coperchio e 1 retino di fondo.*



## Performance *Prestazioni*



58kg



Frozen Chips  
*patatine surgelate*



1 h

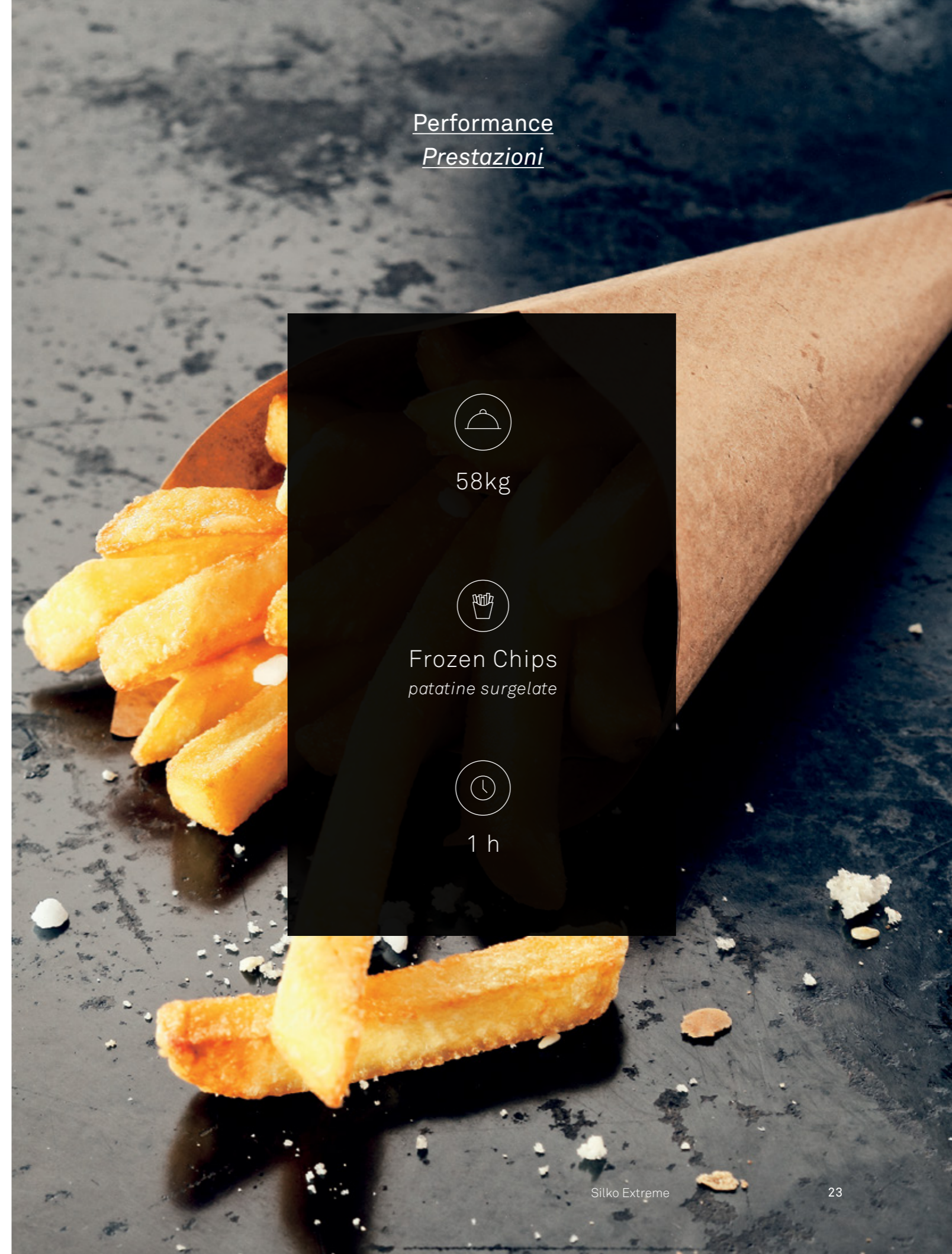

## Electric fry top

## Fry top elettrico

Available with smooth chrome-plated cooking surface, or with chrome-plated half-ribbed half-smooth chrome surface. Three cooking zones with nine embedded heaters in cast aluminum, thermostatic control from 110° C to 280° C, possibility of raising the plate for cleaning and maintenance, cooking surface 1110 x 644. Supplied with scraper or spatula and grease collection drawers.

Disponibile con piastra liscia cromata oppure con piastra mezza liscia e mezza rigata, cromata. Tre zone di cottura con nove resistenze inglobate in una fusione d'alluminio, regolazione termostatica da 110°C a 280°C, possibilità di alzare la piastra per la pulizia e manutenzione, superficie di cottura 1110x644 mm. Fornito con raschietto o paletta per la pulizia della piastra e cassette raccolta grassi.



## Performance

### Prestazioni



45



Frozen Hamburger  
(Ø 120mm / h 10mm)

*hamburger congelato*



1 h



230°



## Gas grill

### Griglia gas

Gas grill with a large cast iron cooking surface to ensure maximum thermal efficiency by maintaining constant temperature over the entire surface. Four cooking zones: cooking surface 1080x 535. Four high efficiency burners made of cast iron, protected by the radiant elements to ensure a high thermal delivery. Equipped with fat collection drawer.

*Griglia gas con ampia superficie di cottura in ghisa per assicurare la massima resa termica grazie al mantenimento costante della temperatura su tutta la superficie. Quattro zone di cottura: superficie di 1080x 535 mm. Quattro bruciatori ad alta efficienza realizzati in ghisa, protetti da elementi radianti atti a garantire un elevato volano termico. Fornito di cassette raccolta grassi.*



## Fry top gas

### Fry top gas

Versions: Smooth griddle or half-ribbed half-smooth surface, available also in chrome-plated. Three cooking zones with 3 adjustable burners, thermostatic regulation from 110°C to 280°C, ability to lift the plate (by means of the hinges) for maintenance, cooking surface 1110cm x 644cm. Supplied with scraper or scoop for the cleaning of the plate and grease collection drawers.

*Versioni: piastra liscia o piastra mezza liscia e mezza rigata disponibili anche nella versione cromata. Tre zone di cottura con 3 bruciatori regolabili termostaticamente da 110°C a 280°C, possibilità di alzare la piastra (tramite delle cerniere) per la manutenzione, superficie di cottura 1110x 644 mm. Fornito con raschietto o paletta per la pulizia della piastra e cassette raccolta grassi.*

## Electric multi-cooking

### Multicooking elettrica



One machine for many uses. The needs of the market and of the consumer have changed, and today they are quantitatively and qualitatively more evolved than in the past: great importance is given to variety, nutritional value, best use of resources, safety, reliability and convenience. Multi Cooking lends itself to this, becoming a grill, deep fryer, fry top, pasta cooker, even allowing pressure cooking, with the use of a special cover, to shorten cooking times. The technology permits healthy cooking, thanks to uniform temperatures across the cook top, and to the possibility of performing delicate low temperature cooking with steam or in a vacuum, allowing the food to maintain its nutritional properties, and avoiding a fall in weight. It is also possible to simultaneously manage different foods or sizes of pieces thanks to the core probe and the multi-probe.

*Un'unica macchina per tanti utilizzi. Le esigenze del mercato e del consumatore si sono trasformate e oggi sono quantitativamente e qualitativamente più evolute rispetto al passato: grande importanza viene data all'ampia proposta gastronomica, ai valori nutrizionali, all'ottimizzazione delle risorse, alla sicurezza, all'affidabilità ed alla convenienza. Proprio per questo la Multi Cooking si presta a diventare brasiera, friggitrice, fry top, cuocipasta fino a permettere l'utilizzo del coperchio a pressione per abbreviare i tempi di cottura. La tecnologia impiegata permette una cottura molto più salutare grazie a temperature uniformi su tutto il piano della vasca e alla possibilità di effettuare cotture delicate a bassa temperatura, a vapore oppure in sottovuoto; il cibo mantiene quindi inalterate le proprietà nutritive, evitando il calo peso. E' inoltre possibile gestire in contemporanea diversi alimenti o pezzature grazie alla sonda al cuore e alla multisonda.*

## Operating method

### > Boiling in water and the bain marie

Boiling, blanching, poaching, blanching, water bath.

### > Steam cooking and pressure cooking

Steam cooking and pressure cooking steam, vacuum cooking and pot technique cooking.

### > Frying

Sauteeing, frying.

### > Cooking direct heat

Grill or griddle, with grilling marks.

### > Mixed cooking methods with / without pressure

Cook in pan, braise, stew, glazing.

### > Technologies

Pot technique technology - cooking, vacuum cooking.

### > Systems

Cook & Chill Systems, Cook & Freeze, overnight cooking, pasteurization, thawing, regeneration and maintenance.

Intuitive touch screen panel to view and insert programs, clearly showing the functions and cycles active by illumination of the corresponding icon.

USB connection for updating programs and recipes preloaded.

Multilingual menu (EN FR DE IT ES).

### Equipment of the series

filter with probe insertion support.

## Modalità di funzionamento

### > Bollitura in acqua e bagnomaria

Bollire, sbollentare, affogare, sbiancare, bagnomaria. Livello max di utilizzo 20 lt.

### > Cotture a vapore e vapore con pressione

A vapore, a vapore con pressione, cottura sottovuoto e vasocottura. Livello max 3 lt.

### > Friggere

Cuocere al salto, friggere.

Livello di utilizzo per questa funzione min 11 lt max 12 lt.

### > Cottura a calore per contatto

Grigliata, piastra, segnature.

### > Cotture miste senza/con pressione

Cuocere in pentola, brasare, stufare, glassare.

### > Tecnologie

Vasocottura, cottura in sottovuoto.

### > Sistemi

Cook&Chill, Cook&Freeze, cottura notturna, pastorizzazione, scongelamento, rigenerazione e mantenimento.

Intuitivo pannello touch screen per visualizzare ed inserire i programmi, chiara visualizzazione delle funzioni e dei cicli attivi grazie all'illuminazione dell'icona corrispondente.

Connessione USB per aggiornamento dei programmi e delle ricette precaricate.

Menù multilingua (EN DE FR IT ES).

### Dotazione di serie

Filtro con supporto inserimento sonda.



180  
portions  
*porzioni*



Risotto



1h



100  
portions  
*porzioni*



Stuffed  
*brasato*



1h

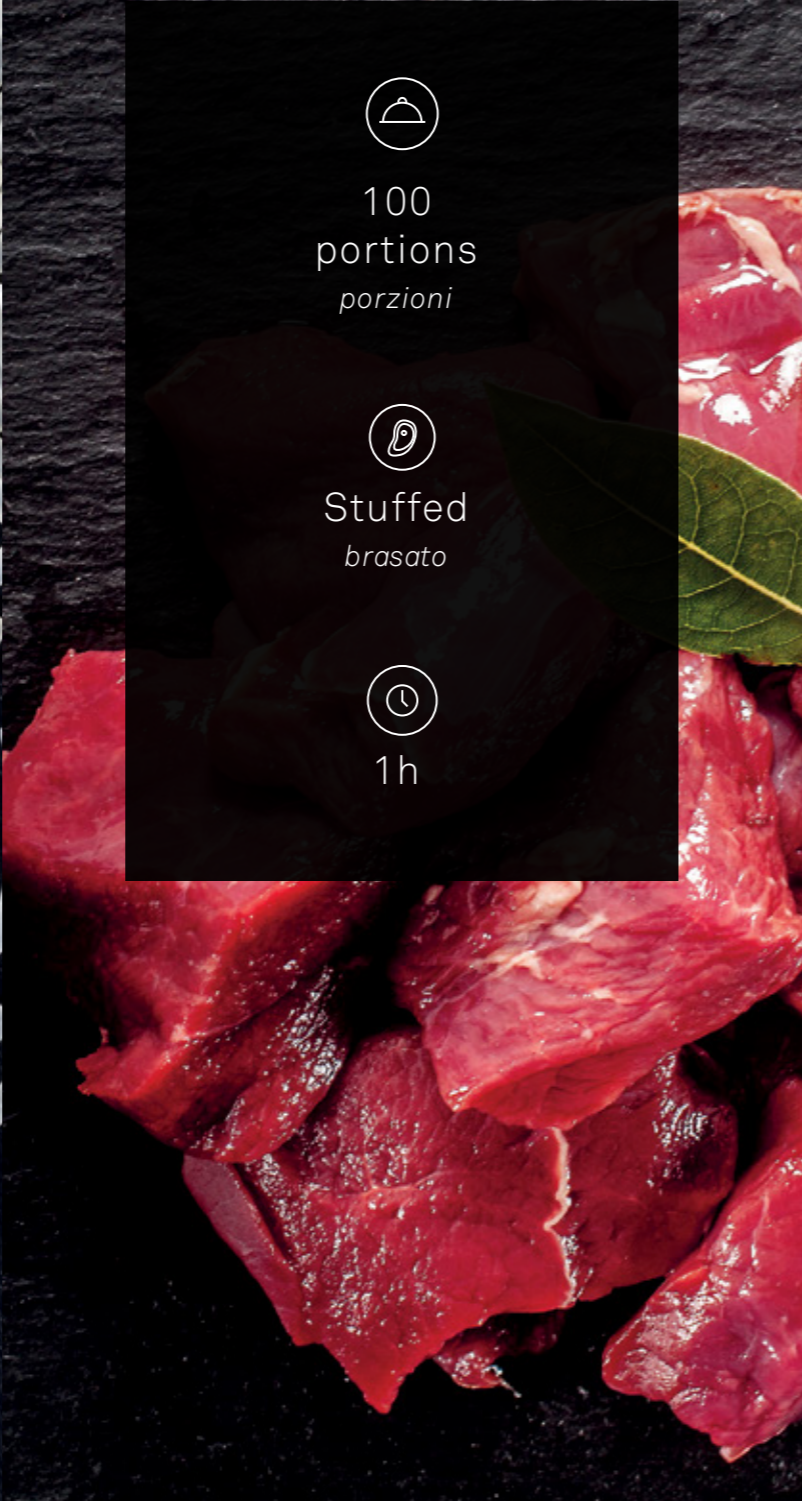

75  
portions  
*porzioni*



French Fries  
*patatine*



1h

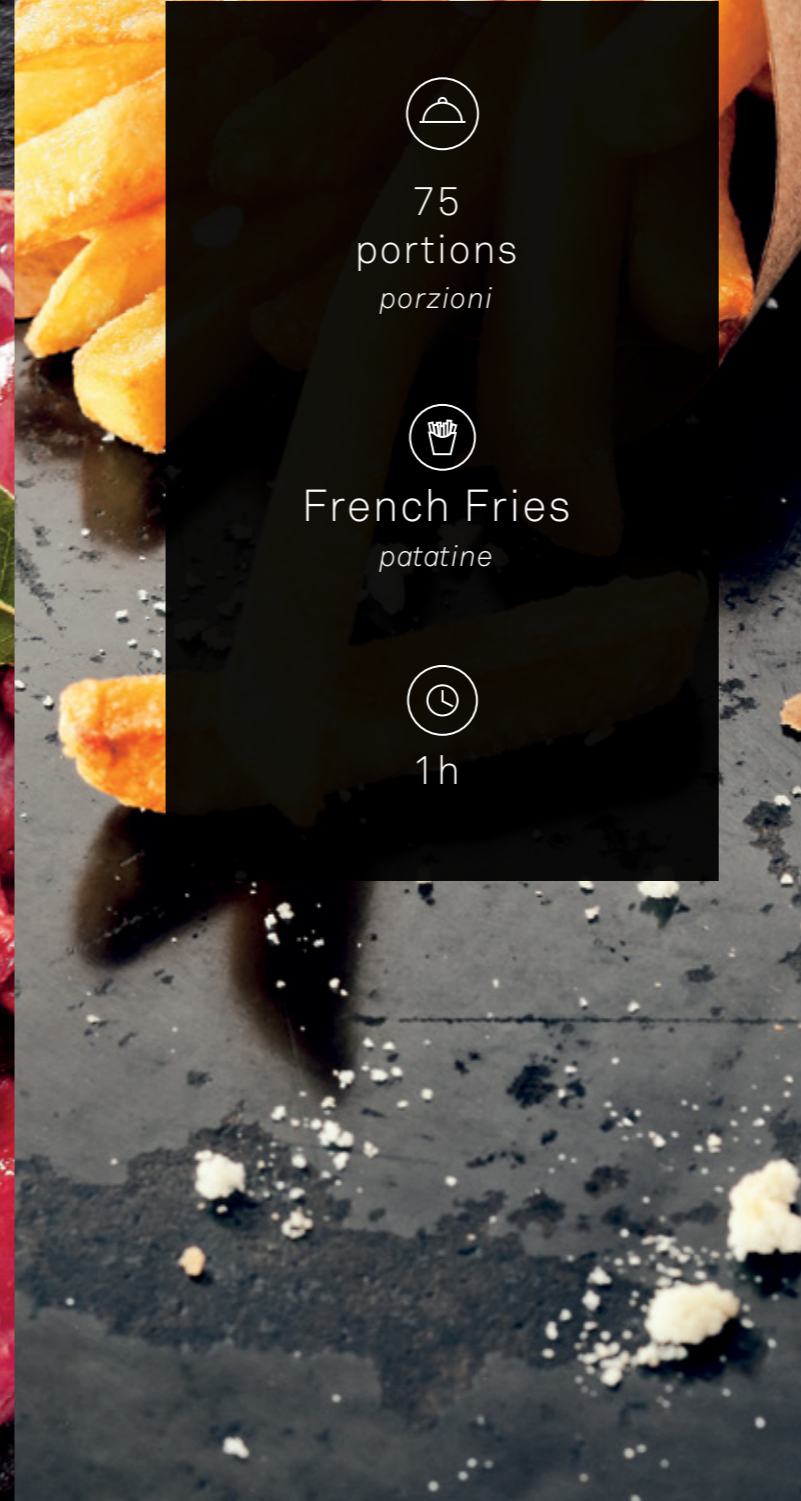

100  
portions  
*porzioni*



Ragout  
*ragù*



1h

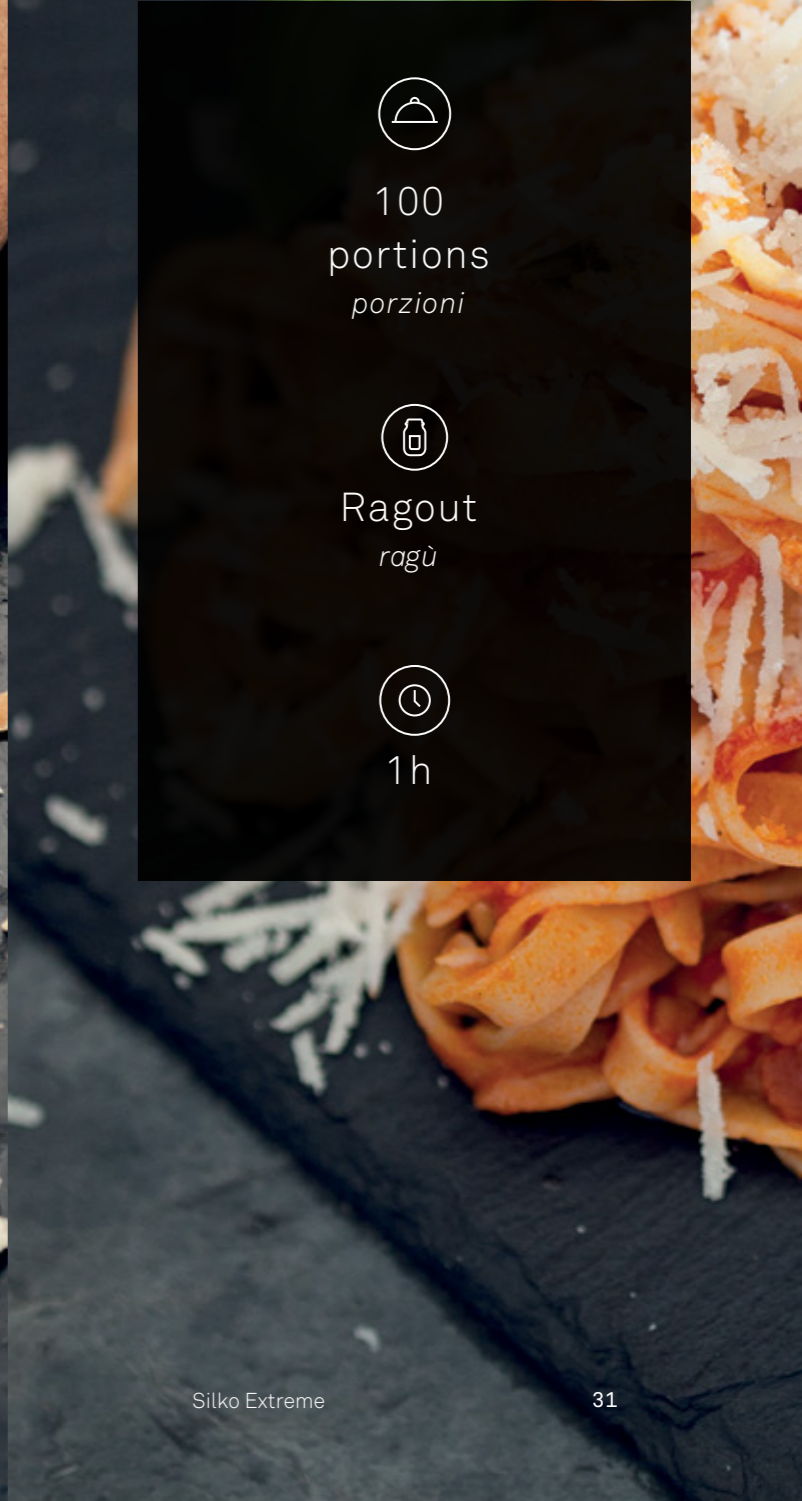



## Plancha

### Plancha

Versatile and powerful, a solid top new design suitable for cooking directly and indirectly. Large work surface (83cmx66cm) with tempered chromium treatment to ensure maximum resistance to high temperatures, and a reduction of heat dissipated into the environment. Four independent cooking zones 4 kw each controlled by an operating thermostat, adjustable from 50° C to 400° C. Peripheral channel suitable for the collection of fats, with a drain hole in the collection box provided.

*Versatile e potente, un tuttapietra di nuova concezione adatto alla cottura diretta ed indiretta. Ampia superficie di lavoro (830x660 mm) con trattamento al cromo temperato per garantire la massima resistenza alle alte temperature e la riduzione del calore dissipato in ambiente. Quattro zone di cottura indipendenti da 4 kw cad. controllate da un termostato di funzionamento regolabile da 50°C a 400°C. Canalina perimetrale atta alla raccolta dei grassi con foro di scarico nel cassetto di raccolta in dotazione.*



## Salamander

### Salamandra

Super-fast, electric and movable, it is made of stainless steel. It is ideal for browning or heating plates. Equipped with a control panel for setting the time and temperature, with digital information display. It can store program sequences and cooking preference cycles, making repeat selection easier. Thanks to the heating by means of special heating elements protected by a ceramic surface, this system allows an exceptional rate of heating and startup system of 230° in a few seconds.

It enables significant energy savings because the equipment can be quickly turned on only when needed. The upper floor is sliding on rails and can be positioned at different heights. Grill and stainless steel basin GN 1/1 are removable for cleaning. They can be placed on a counter top thanks to their rubber feet.

*Ultrarapida, elettrica e mobile, è realizzata in acciaio inox. È ideale per gratinare, riscaldare i piatti. Dotata di pannello comandi per l'impostazione dei tempi e della temperatura, con visualizzazione dei valori nel display digitale. È possibile memorizzare le sequenze dei programmi e cicli di cottura preferenziali, rendendone ripetibile la selezione. Grazie al riscaldamento per mezzo di speciali resistenze protette da una lastra in vetroceramica, questo sistema garantisce un'eccezionale velocità di riscaldamento e di messa a regime di 230° in pochi secondi; inoltre consente un notevole risparmio energetico in quanto l'apparecchiatura può essere rapidamente accesa solo al bisogno. Il piano superiore è scorrevole su guide e posizionabile a diverse altezze. Griglia e bacinella in acciaio inox GN 1/1 estraibili per la pulizia; possono essere appoggiate su banco grazie ai piedini in gomma.*

## Refrigerated bases

### — *Basi refrigerate*

Refrigerated counters designed to support top features of the Extreme product line, in variations in TN or BT. 2 telescopic drawers in stainless steel, capacity GN2 / 1 allow a large storage, accessible with ease. Refrigeration is ventilated, and the automatic evaporation of the defrosting water is guaranteed by the electronic temperature control.

—  
*Basi refrigerate progettate per supportare le funzioni top della gamma Extreme, nelle varianti TN o BT. Per garantire il massimo stoccaggio accessibile con estrema semplicità, le basi sono dotate di 2 cassetti di capacità GN 2/1 che vengono montati su guide telescopiche in inox. La refrigerazione ventilata e l'evaporazione automatica dell'acqua di sbrinamento sono garantite dal controllo elettronico della temperatura.*



## Floor Stand

### — *Base Cavalletto*

Stands designed to support the top functions of the Extreme product line. Made of sturdy stainless steel tube.

—  
*Supporti progettati per supportare le funzioni top della gamma Extreme. Realizzati in robusto tubo di acciaio inox.*



# Accessories

## Accessori

### FRYTOP

#### Drawer for cleaning *Cassetto per pulizia*

Large capacity drawer for the collection of cooking residue during the operation of cleaning the griddle.

*Cassetto di grande capacità per la raccolta dei residui di cottura durante le operazioni di pulizia della piastra.*

#### Scraper for cleaning *Raschietto per pulizia*

Scraper for the cleaning of the griddle during cooking and after, available for both solid and ribbed griddles.

*Raschietto per la pulizia della piastra durante la cottura e a fine lavoro, disponibile sia per piastra liscia che rigata.*

#### Couple of drain stoppers for cleaning *Coppia tappi per pulizia*

Teflon drain stoppers for closing drains to perform cleaning operations.

*Coppia di tappi in teflon adatti a chiudere il foro di scarico al fine di agevolare le operazioni di pulizia.*

### MULTICOOKING

#### Bottom grill *Griglia di fondo*

Bottom grill ideal for indirect cooking.

*Griglia di fondo adatta alle cotture indirette.*

#### Kit of 2 baskets *Kit 2 cestini*

For use in the fryer, kit 2 baskets of 1/2 cooking capacity each.

*Per funzione friggitrice, kit 2 cestini da un mezzo.*

#### Kit of 3 baskets *Kit 3 cestini*

For use in the pasta cooker, kit 3 baskets of 1/3 cooking capacity each.

*Per funzione cuocipasta, kit 3 cesti da 1/3.*

### FRYER FRIGGITRICE

#### Skirting perimeter *Zoccolatura perimetrale*

To ensure maximum hygiene in the kitchen.

*Per assicurare maggior igiene in cucina.*

### FLOOR STAND CAVALLETTO

#### Shelves *Ripiani*

Lower shelf of the floor stand.

*Ripiano di fondo per base cavalletto.*

#### Tray holder *Supporto Teglie*

Tray holder frame for floor stand.

*Portateglie per base cavalletto.*

### MULTICOOKING

#### Kit of 3 baskets *Kit 3 cestini*

Kit 3 baskets of 1/3 cooking capacity each, for steam cooking vegetables, fish and cereals.

*Kit 3 cesti da 1/3 per la cottura a vapore di verdure, pesce e cereali.*

#### Palette *Paletta*

Palette to clean the bottom of the basin.

*Paletta per la pulizia del fondo vasca.*

**Silko - Ali S.p.A.**  
Via Cal Larga, 8  
Z.I San Giacomo di Veglia  
31029 Vittorio Veneto (TV) ITALY  
T (+39) 0438 911930  
F (+39) 0438 506291  
info@silko.it  
[www.silko.it](http://www.silko.it)

Silko is a Company of   
G R O U P

Art Direction & Graphic Design  
Hangar Design Group

SILKO